



Dear Customer,

Thank you for purchasing Lopolight's unique navigation light.

Lopolight products are covered by a 5-year limited warranty.

Read more about Lopolight at www.lopolight.com.

This sheet is a general guideline showing hints and examples. Some of the examples shown may not comply fully with your Lopolight model. The general idea is that the mounting base can be shaped by the user to fit any individual mast. You can drill – cut and shape the base in any way you like, but do not destroy the 3 predrilled M4 holes. Remember that we have put a lot of effort into making Lopolight as reliable as possible – and emphasize the importance of making a proper and thorough installation of both mechanical and electric parts. Good luck!

Please do NOT use alcohol for cleaning your Lopolight – this could damage the lens.

1. Remove old masthead light, and determine if the existing holes can be used. Drill new holes if necessary.
2. Mark the holes in the mounting base. The measurement taken under point 1 must now be marked on the mounting base.
3. Drill new holes in the mounting base.
4. Connect the power cable to your onboard system. The BLACK lead is the ground, the RED lead marked is the positive (+). If your light has a secondary function (ex. Anchor light) the WHITE lead will be the positive (+) for this function. Please make sure that you select the correct fuse, typically 1A, never more than 2A. Please protect the power cable from chafe and route it away from sources of heat and large magnetic fields such as electric motors.
5. Make sure polarity is correct - Your Lopolight LED nav-light will only function if the polarity is correct. All Lopolight products accept any voltage between 10 and 32 Volt.
6. The Lopolight can now easily be fitted on to the base, using the three pre-drilled M4 holes. The base can be shaped in any suitable way to fit your needs.

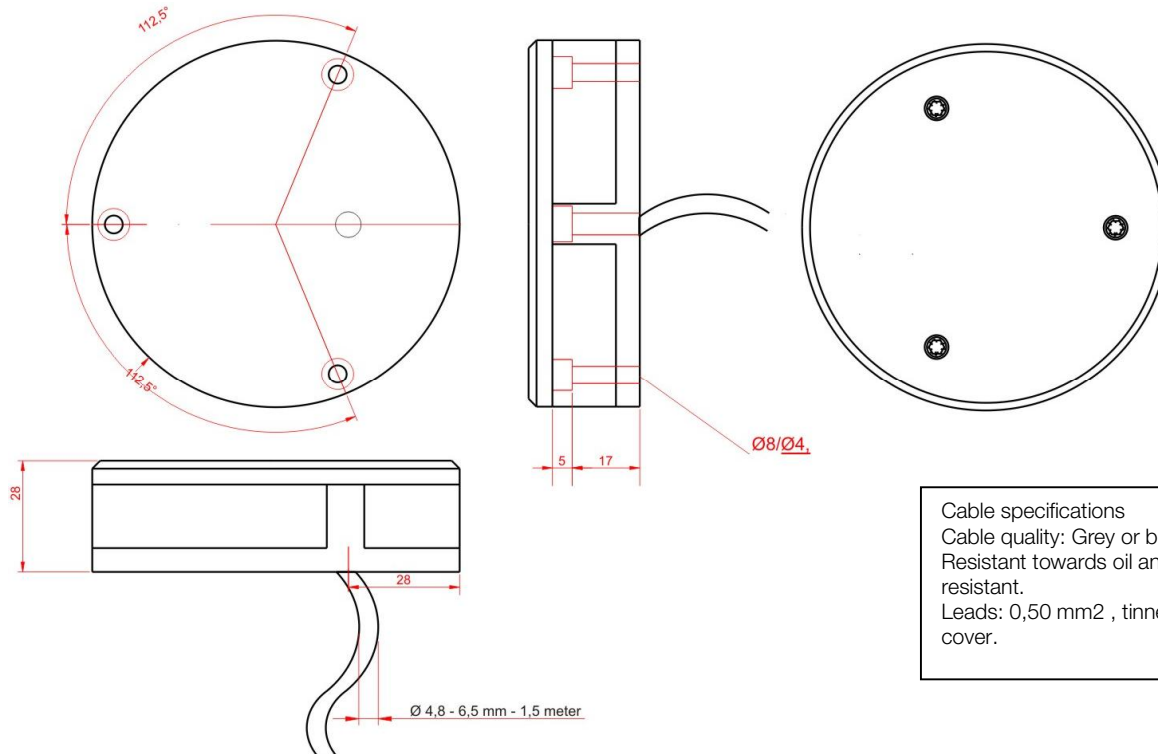

Cable specifications
 Cable quality: Grey or black PUR cover.
 Resistant towards oil and water, and flame resistant.
 Leads: 0,50 mm² , tinned copper, PVC cover.

The navigation light should not be grounded.

Troubleshooting

If the light does not function:

- Check that you have a voltage between 10 and 32 volts.
- Check that the polarity is right.

End of life signalling:

Your Lopolight product has a microprocessor inside that ensures that the light has the same intensity over its 50.000 hour lifetime. The light will signal to you when it is getting to the end of its useful life.

The following signals can be seen:

All OK: 5 seconds after turning on the light it will go dark for 0,1 second and turn on again. This is just a check for you to assure that the microprocessor is working.

Less than 2000 working hours left: The dark period is extended to **2 seconds**: You should change the light at your next service within the next 12 months.

Light expired: The dark period is extended to 5 **seconds**: You should change the light immediately.

Type approval:

The light in this package complies with the following standards: EN-14744, UL-1104, COLREG72, IEC 60945

The light in this package is recognized by the following major national maritime authorities:

- MCA (UK), QQ-TAN-03/05-01R
- USCG (USA), approved 09-2005 under 111.075 by recognized laboratory QinetiQ