

Installation instructions for Lopolight navigation lights 300-036 5nm masthead, horizontal mount

Dear Customer,

Thank you for purchasing a Lopolight LED navigation light.

The Lopolight products are covered by a 5-year limited warranty. This warranty covers direct exchange of the malfunctioning product and is given under the assumption that the lights have been operated within the specifications of lights.

Mechanical mounting:

Please consult the supplied assembly drawing (see rear side). The bolts used for attaching the light onto the vessel should be with a cylindrical head such as a M6 unbrako (DIN 912) A4 in appropriate length – these bolts are not supplied with the light.

Mounting on dissimilar materials should only be done with a suitable corrosion barrier between the light and the vessel.

Navigation lights are category C (exposed to weather) devices.

Alignment to vessel centreline:

In order to comply with regulations it is necessary to align the light carefully along the centreline of the vessel, the 0 line marked on the light should be used for this. It is desirable that the design of the fitting/vessel assists with cutting off the light beam at the appropriate angles (225° for masthead lights).

Electrical connection:

The light has a space for connecting the ships cable into the light. This space is placed at the bottom or the rear of the light.

This cable mounting space is IP68 waterproof under the assumption that the supply cable diameter is between 5mm and 9mm and that the supplied O-ring between Lopolight and cable assembly bay is mounted correctly.

The supplied cable glands and blinding caps should be mounted to create the desired cable run and ensure the waterproof properties of the light.

Please consult the attached assembly drawing for further details (see rear side). The detachable green connector plug (supplied) has to be connected to the ships cable according to the figure to the right.

The light will only function if the polarity is correct. (you cannot damage the Lopolight by accidentally wiring the polarity wrong – it will just not work). The navigation light should not be grounded.

Masthead, single P/N300-036 (5nm) +24VDC J1 1: +24VDC prim. masth 2: GND prim. masth 3: nc 4: nc 5: nc

www.lopolight.com

Troubleshooting:

If the light does not function:

- Check that you have a voltage between 22 and 31 volts.
- Check that the polarity is right.

End of life signalling:

Your Lopolight product has a microprocessor inside that ensures that the light has the same intensity over its 50.000 hour lifetime. In addition the light will signal to you when it is getting to the end of its useful life.

The following signals can be observed when turning on the light:

- (a) All OK: 5 seconds after turning on it will go dark for 0,1 second and turn on again.
- (b) Less than 2000 hours left: The dark period is extended to **2 seconds: You should replace the light at your next service within the next 12 months.**
- (c) Light expired: The dark period is extended to **5 seconds: You should replace the light immediately.**

Monitoring and Control from bridge:

Instead of the visual control implied in the above section on “end of life signalling” Lopolight offers a monitoring module built to class (LR) specifications for bridge panel applications. Each monitoring module (Lopolight part number 400-018) monitors one light for the messages sent by the light over the power wire and will trigger the alarm in the case of situation (b) and (c). In addition to this the monitoring module will alarm if the power is cut or shortened or if the light has a partial failure.

Service:

Please consult ships GA drawing for location of the light, the part number (see top right of page) is engraved on top of the light.

To remove the light unfasten the 3 bolts and disconnect the cable.

The light is constructed so that it can be removed and reinstalled without recalibration. The mounting system ensures precise angulation of the light beam when reinstalling. No user-serviceable parts in the light thus there nothing to repair, in case of failure light has to be replaced in its entirety, the part number can be found on top of the light and at the top right corner of this guide.

Conformity to standards:

The light in this package comply with the following standards:

Navigation light functions and qualities: EN-14744, COLREG72.

EMC, Conducted Emissions: IEC 60945

EMC, Radiated Emissions: IEC 60945

EMC, Conducted RF Immunity: IEC 60945

Vibration: EN-14744

Solar radiation: EN-14744

Temperature range: EN-14744: energized: -25° to +55°C

Products will work energized: -35° to +75°C*

*(based on tests in -40° to +80°C for 200 hours in controlled climate chamber)

Waterproof: According to IEC 60945 and IP68

Approvals:

Type approval MED1350099, Wheelmark (MED) type approval pending, test rapport DANAK-19/12702.

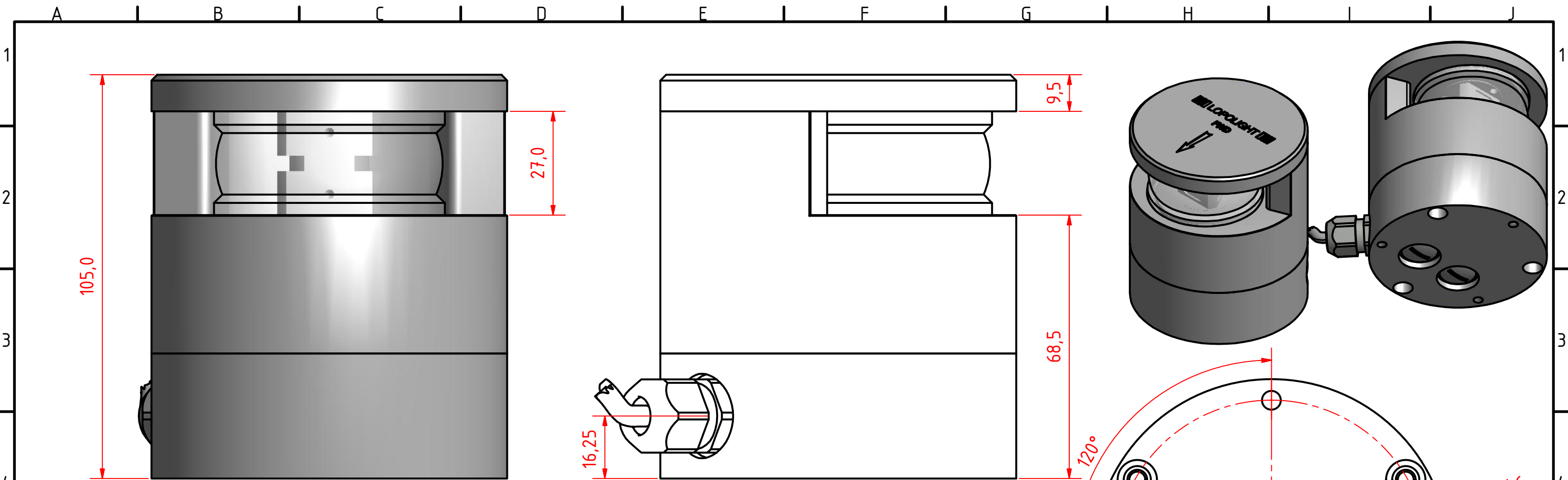

Cable Glands in nickle plated brass. Cable exit can be established as port or starbord aft exit, or port or starboard cable down versions. This lantern can also be mounted on Lopolight mouting flange model nr. 400-401 to allow securement from abov.

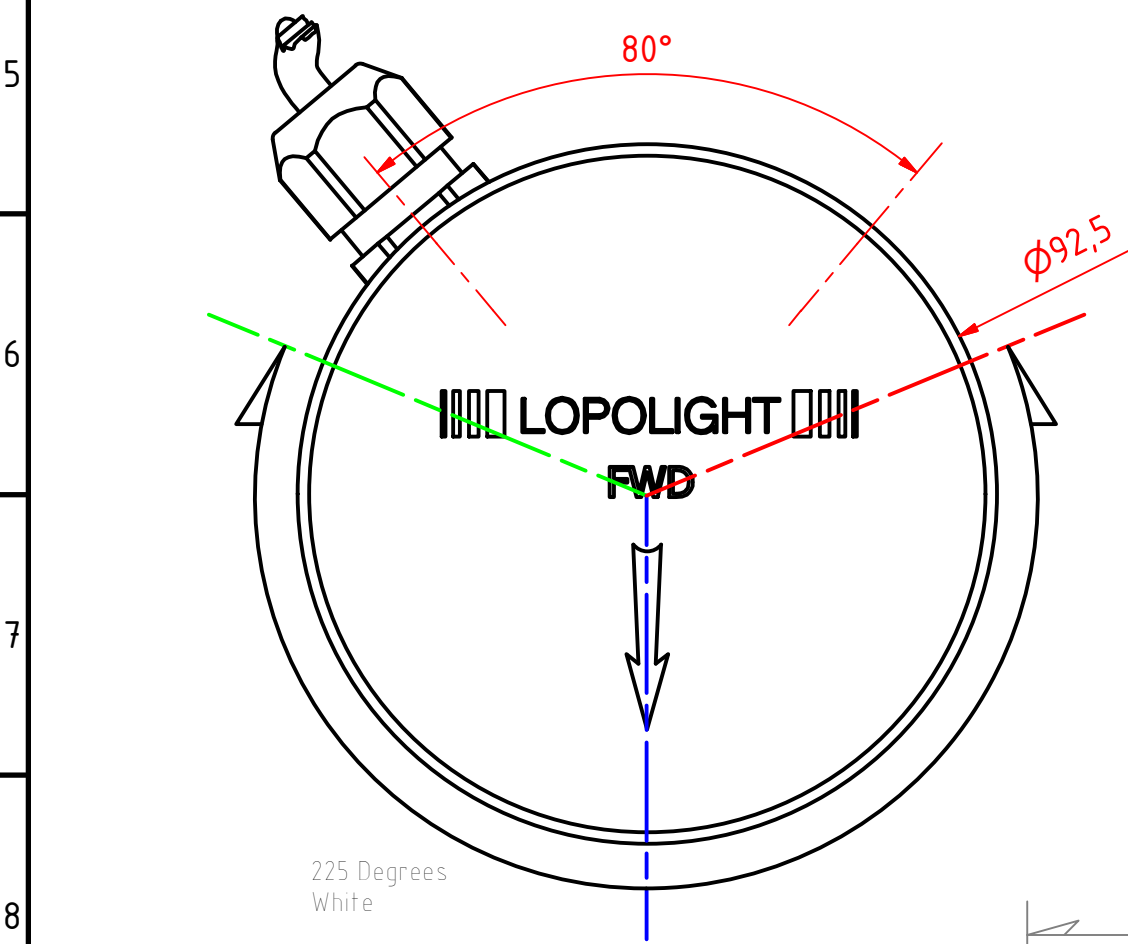

M16 X 1,5mm Cabel Gland

M6x1 - 6H

300-036 5nm Masthead, Horizontal Mount

DRAWING NO.: 300-036	REV. NO.:	SIZE: A3	DRAWN BY: Paul
SCALE: 1:1	TOLERANCES: DS/ISO 2768-f	REVIEWED BY: PHH	

MATERIAL DESCRIPTION:
Aluminium

This Drawing, and the information within, is the property of Lopolight ApS and may not be used in any form without express permission there from. Lopolight reserves the right to change this drawing and assumes no liability for the information communicated herein. Use of dimensions and other information in this drawing is at the users own risk.

LOPOLIGHT

Lopolight ApS
Ved Klaedebo 12
DK-2970, Hoersholm
Denmark

www.lopolight.com

Tel:(+45) 32 48 50 30 Fax:(+45) 32 48 50 32
info@lopolight.com

50MM AT A3