

1 2 3 4 5 6

REVISIONS				
ZONE	REV.	DESCRIPTION	DATE	APPROVED
	A	NEW PART	10-5-16	

A
B
C
D

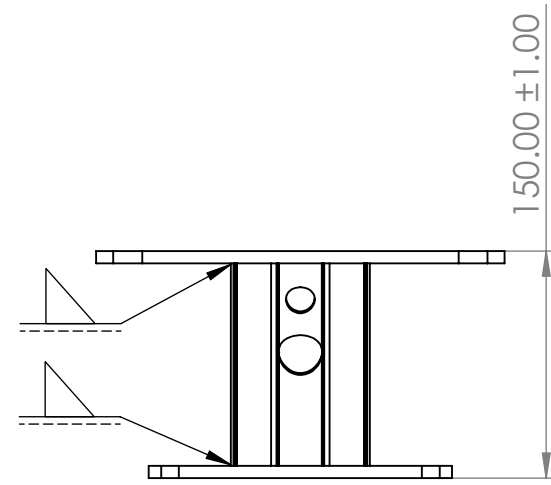
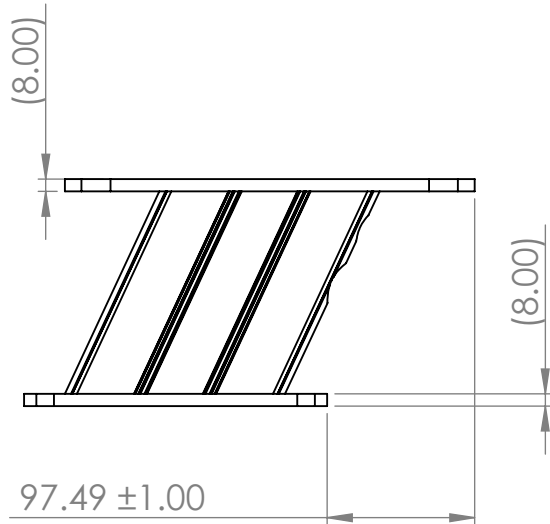
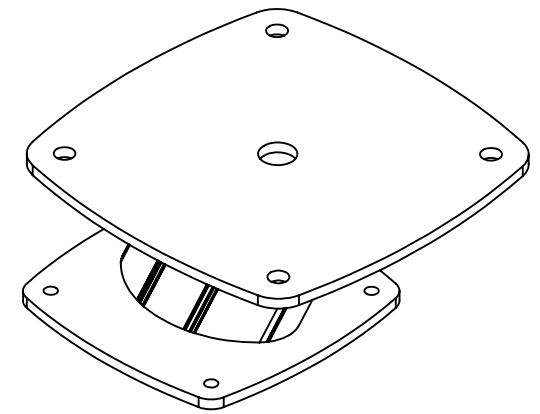
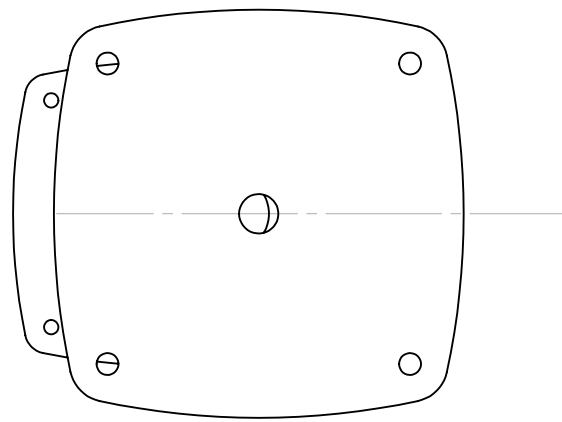

NOTES

1. DATA CONTROLLED BY SCANSTRUT ENGINEERING DEPARTMENT: CAD MODEL IS MASTER.
2. CRITICAL AND IMPORTANT DIMENSIONS SHOWN: PART IS CONTROLLED BY CAD DATABASE.
3. FILLET WELD ALL JOINTS

SCANSTRUT			
DESIGN COPYRIGHT OF SCANSTRUT LTD			
SCALE:1:5	A4		DO NOT SCALE DRAWING
UNLESS OTHERWISE SPECIFIED: DIMENSIONS ARE IN MILLIMETERS		GENERAL TOLERANCES: ±0.1 UNLESS OTHERWISE STATED. IF IN DOUBT PLEASE ASK	
TITLE:		APT6004 fabrication	
PART NO.	1016004	REVISION	A
DRAWN	GB	DATE	10/05/16
SHEET 1 OF 1			

MATERIAL: 6082 Aluminium Fabrication	FINISH: Powder Coat Gloss White	DEBUR AND BREAK SHARP EDGES
---	------------------------------------	-----------------------------------