

SITEX[®]



NMEA-2000 Version

Vector Compact GPS Compass User Guide

Part No. 875-0347-0 Rev. A1

This device complies with part 15 of the FCC Rules. Operation is subject to the following two conditions:

- (1) This device may not cause harmful interference, and
- (2) this device must accept any interference received, including interference that may cause undesired operation.

Trademarks

Hemisphere GNSS[®], SI-TEX Marine Electronics logo, COAST[™], PocketMAX[™], Crescent[®] and Vector[™] are proprietary trademarks of Hemisphere GNSS, Inc. Other trademarks are the properties of their respective owners.

Patents

This product may be covered by one or more of the following patents:

<u>U.S. Patents</u>					<u>Australia Patents</u>
6111549	6876920	7400956	8000381	8214111	2002244539
6397147	7142956	7429952	8018376	8217833	2002325645
6469663	7162348	7437230	8085196	8265826	2004320401
6501346	7277792	7460942	8102325	8271194	
6539303	7292185	7689354	8138970	8307535	
6549091	7292186	7808428	8140223	8311696	
6711501	7373231	7835832	8174437	8334804	
6744404	7388539	7885745	8184050	RE41358	
6865465	7400294	7948769	8190337		

Other U.S. and foreign patents pending.

Documentation Feedback

SI-TEX Marine Electronics is committed to the quality and continuous improvement of our products and services. We urge you to provide SI-TEX Marine Electronics with any feedback regarding this guide by writing to the following email address: customerservice@si-tex.com.

Contents

Chapter 1	Introduction	
	Overview.....	2
	Parts List.....	3
Chapter 2	Vector Compact (n2k) Installation	
	Mounting Location.....	6
	GPS Reception.....	6
	Vector Compact (n2k) Environmental Considerations.....	6
	VHF Interference	7
	Mounting Orientation.....	9
	Vector Compact (n2k) Alignment	11
	Mounting Options.....	12
	Vector Compact (n2k) Dimensions	12
	Cable Considerations	14
	Flush Mount	15
	Pole Mount	17
	Powering and Connecting to the Vector Compact (n2k).....	20
	Power Considerations.....	20
	Electrical Isolation.....	20
	NMEA 2000 Port.....	21
Chapter 3	Operation	
	GPS Overview.....	24
	GPS Operation	24

Contents

Differential Operation	25
Vector Compact (n2k) Overview	26
Supplemental Sensors	26
Time Constants.....	29
Watchdog	29
Common Commands and Messages	30
End User License Agreement	47
Warranty Notice	50

Chapter 1: Introduction

Overview

Parts List

Overview

The Vector Compact (n2k)[™] GPS Compass is based upon Hemisphere GNSS' exclusive Crescent[®] and Crescent Vector[™] II technology.

The Vector Compact (n2k) is a complete GPS compass and position system in a single enclosure that requires a standard NMEA 2000 cable connection. With NMEA 2000 support and ease of installation, the Vector Compact (n2k) is the perfect solution for marine-based applications.

The Vector Compact (n2k) is an integrated system that houses the following:

- Crescent and Crescent Vector II technology
- Dual integrated GPS antennas
- Power supply
- Single axis gyro
- Tilt sensor on each axis (X and Y axes)

The gyro and tilt sensors are present to improve system performance and to provide backup heading information in the event that a GPS heading is not available due to signal blockage.

Crescent Vector II technology supports multiple RF front ends - enabling tighter coupling of measurements from separate antennas for use in heading-based products. Users will achieve excellent accuracy and stability due to Crescent's more accurate code phase measurements, improved multi-path mitigation, and fewer components.

The Vector Compact (n2k)'s GPS antennas are separated by 13.5 cm between their phase centers, resulting in better than 2° rms heading performance. The Vector Compact (n2k) provides heading and position updates of up to 10 Hz and delivers position accuracy of better than 1.0 m 95% of the time when using differential GPS corrections from Space Based Augmentation Systems (SBAS).

The Vector Compact (n2k) also features Hemisphere GNSS' exclusive COAST[™] technology that enables SI-TEX Marine Electronics receivers to utilize old differential GPS correction data for 40 minutes or more without significantly affecting the position quality. The Vector Compact (n2k) is less likely to be affected by differential signal outages due to signal blockages, weak signals, or interference when using COAST.

If you are new to GPS and SBAS, refer to the GPS Technical Reference for further information on these services and technologies before proceeding. The GPS Technical Reference is available from the SI-TEX Marine Electronics website at www.si-tex.com

Parts List

Note: The Vector Compact (n2k)'s parts comply with IEC 60945 Section 4.4: "exposed to the weather."

Table 1-1: Parts list for Vector Compact (n2k)

Part Name	Qty	Part Number
Vector Compact (n2k) GPS Compass (NMEA 2000)	1	804-0128-0
Screw Housing Caps	2	675-0173-0
Mounting Screws	2	675-1199-000#
Mounting Base	1	676-0035-0
Mounting Nut	1	676-1021-000#
Screw Housing Cap O-Rings	2	681-1066-0

This User Guide is available for download from the SI-TEX Marine Electronics website at www.si-tex.com

Compact Vector GPS Compass User

Chapter 1: Introduction

Chapter 2: Vector Compact (n2k) Installation

Mounting Location

Mounting Orientation

Mounting Options

Powering and Connecting to the Vector

Compact (n2k) Connecting the V104 to

External Devices

Mounting Location

This section provides information on determining the best location for the Vector Compact (n2k).

GPS Reception

When considering where to mount the Vector Compact (n2k), consider the following GPS reception recommendations:

- Ensure there is a clear view of the sky available to the Vector Compact (n2k) so the GPS and SBAS satellites are not masked by obstructions that may reduce system performance.
- Since the Vector Compact (n2k) computes a position based on the internal GPS antenna element, mount the Vector Compact (n2k) where you desire a position with respect to the GPS antenna (located on the side of the recessed arrow on the underside of the enclosure).
- Locate any transmitting antennas away from the Vector Compact (n2k) by at least several feet to ensure tracking performance is not compromised, giving you the best performance possible.
- Make sure there is enough cable length to tie into the NMEA 2000 backbone of the vessel.
- Do not locate the antenna where environmental conditions exceed those specified in Table B-5 on page 43.

Vector Compact (n2k) Environmental Considerations

The Vector Compact (n2k) is designed to withstand harsh environmental conditions; however, adhere to the following limits when storing and using the Vector Compact (n2k):

- Operating temperature: -30°C to +70°C (-22°F to +158°F).
- Storage temperature: -40°C to +85°C (-40°F to +185°F).
- Humidity: 100% non-condensing.

VHF Interference

VHF interference from devices such as cellular phones and radio transmitters may interfere with GPS operation. For example, if installing the Vector Compact (n2k) near marine radios consider the following:

- VHF marine radio working frequencies (Channels 1 to 28 and 84 to 88) range from 156.05 to 157.40 MHz. The L1 GPS working center frequency is 1575.42 MHz. The bandwidth is +/- 2MHz to +/- 10 MHz, which is dependent on the GPS antenna and receiver design (see next page).
- VHF marine radios emit strong harmonics. The 10th harmonic of VHF radio, in some channels, falls into the GPS working frequency band, which may cause the SNR of GPS to degrade significantly.
- The radiated harmonic signal strength of different brands/models varies.
- Follow VHF radio manufacturers' recommendations on how to mount their radios and what devices to keep a safe distance away.
- Hand-held 5W VHF radios may not provide suitable filtering and may interfere with the Vector Compact (n2k)'s operation if too close.

Before installing the Vector Compact (n2k) use the following diagram to ensure there are no nearby devices that may cause VHF interference.

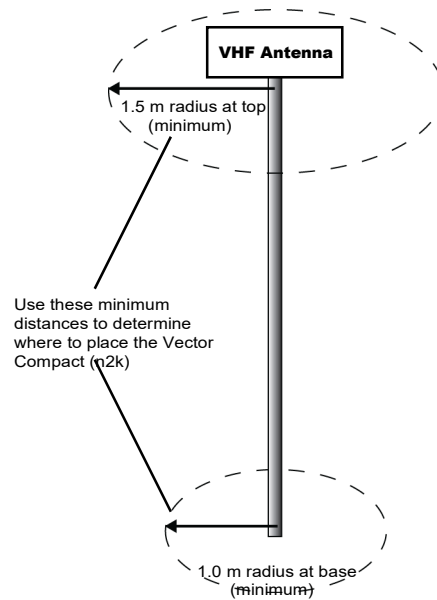

Figure 2-1: Vector Compact (n2k) distance from nearby VHF radios

Mounting Orientation

The Vector Compact (n2k) outputs heading, pitch, and roll readings regardless of the orientation of the antennas. The primary antenna is used for position. The primary and secondary antennas, working in conjunction, output heading, pitch, and roll values.

Parallel Orientation: The most common installation is to orient the Vector Compact (n2k) parallel to, and along the centerline of, the axis of the boat. This provides a true heading. In this orientation:

- If you use a gyrocompass, you can enter a heading bias in the Vector Compact (n2k) to calibrate the physical heading to the true heading of the vessel.
- You may need to adjust the pitch/roll output to calibrate the measurement if the Vector is not installed in a horizontal plane.

Perpendicular Orientation: You can also install the antennas so they are oriented perpendicular to the centerline of the boat's axis. In this orientation:

- You will need to enter a heading bias of $+90^\circ$ if the primary antenna is on the starboard side of the boat and -90° if the primary antenna is on the port side of the boat.
- You will need to configure the receiver to specify the GPS antennas are measuring the roll axis.
- You will need to enter a roll bias to properly output the pitch and roll values.
- You may need to adjust the pitch/roll output to calibrate the measurement if the Vector is not installed in a horizontal plane.

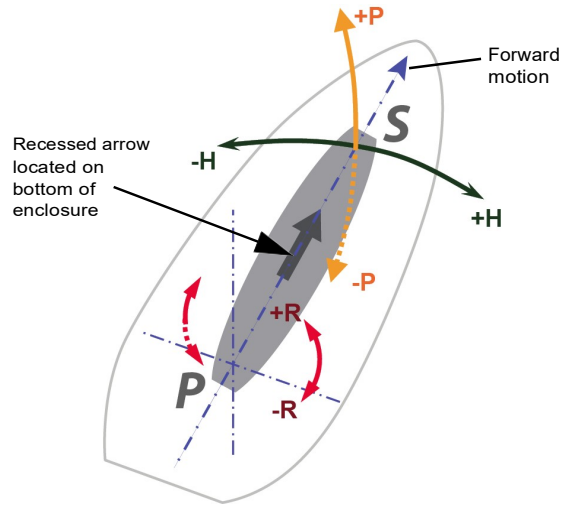

Figure 2-2: Recommended orientation and resulting signs of HPR values

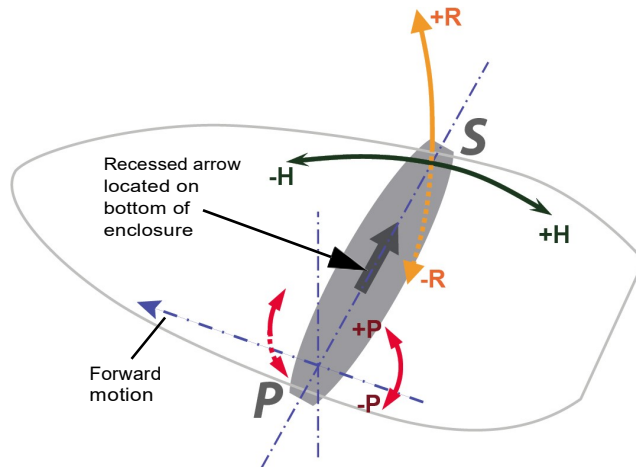

Figure 2-3: Alternate orientation and resulting signs of HPR values

Vector Compact (n2k) Alignment

The top of the Vector Compact (n2k) enclosure incorporates sight design features to help you align the enclosure with respect to an important feature on your vessel.

To use the sights, center the small post on the opposite side of the enclosure from you, within the channel made in the medallion located in the center of the enclosure top as shown in Figure 2-4 and Figure 2-5. Alignment accuracy when looking through the site (Figure 2-4) and (Figure 2-5) is approximately $\pm 1^\circ$.

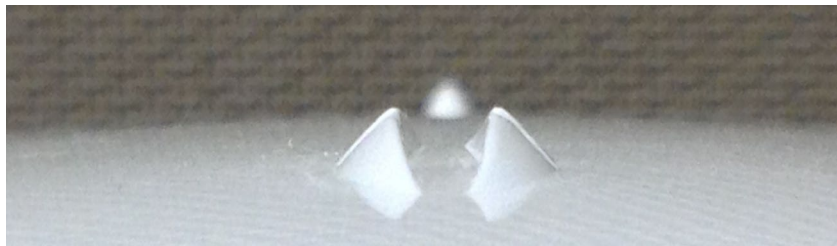

Figure 2-4: Long site alignment channel



Figure 2-5: Long sight alignment center post

If you have another accurate source of heading data on your vessel, such as a gyrocompass, you may use its data to correct for a bias in Vector Compact (n2k) alignment within the Vector Compact (n2k) software configuration. Alternatively, you can physically adjust the heading of the Vector Compact (n2k) so that it renders the correct heading measurement; however, adding a software offset is an easier process.

Mounting Options

The Vector Compact (n2k) allows for both pole or flush mounting. Follow directions below for detailed mounting directions.

Vector Compact (n2k) Dimensions

Figure 2-6 and Figure 2-7 illustrates the physical dimensions of the Vector

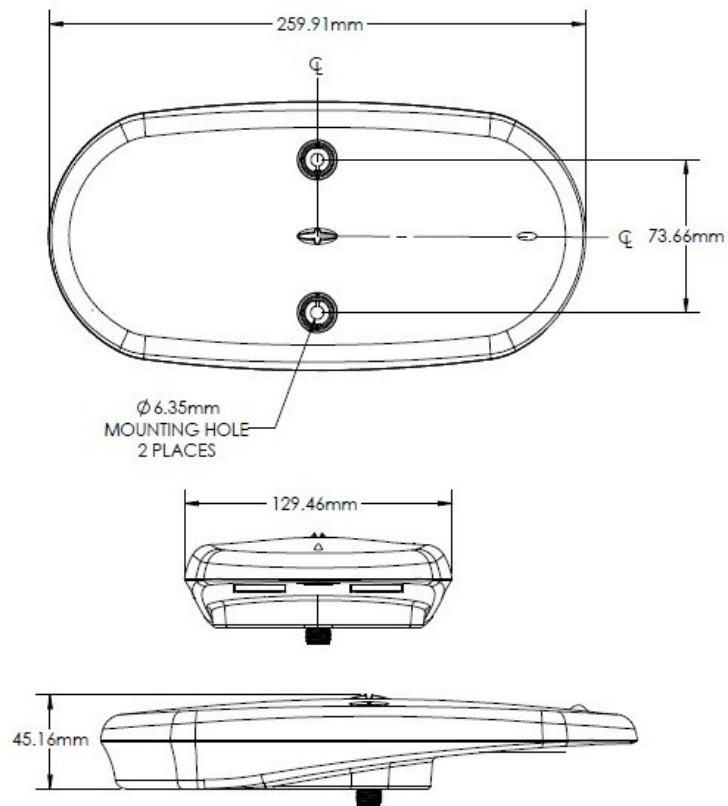

Compact (n2k).

Figure 2-6: Vector Compact (n2k) dimensions

Chapter 2: Installation

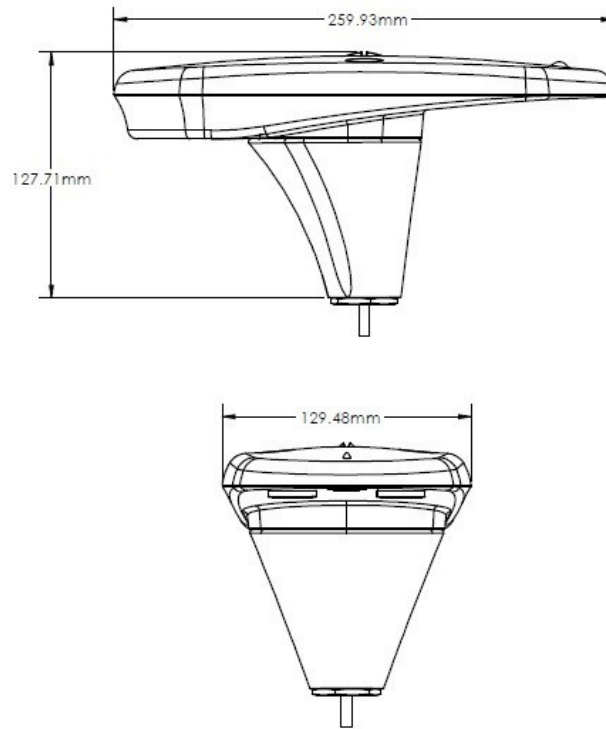

Figure 2-7: Vector Compact (n2k) Dimensions with Adapter

Cable Considerations

Before mounting the Vector Compact (n2k) consider the following regarding cable routing:

- Avoid running the cable in areas of excessive heat
- Keep cable away from corrosive chemicals
- Do not run the cable through door or window jams
- Keep cable away from rotating machinery
- Do not crimp or excessively bend the cable
- Avoid placing tension on the cable
- Remove unwanted slack from the cable at the Vector Compact (n2k) end
- Secure along the cable route using plastic wraps

⚠ WARNING: Improperly installed cable near machinery can be dangerous

Flush Mount

The bottom of the Vector Compact (n2k) contains two holes for flush mounting the unit to a flat surface (Figure 2-8). The flat surface may be something you fabricate per your installation, an off-the-shelf item (such as a radar mounting plate), or an existing surface on your vessel.

Note: SI-TEX Marine Electronics does not supply the mounting surface hardware. You must supply the appropriate fastening hardware required to complete the installation of the Vector Compact (n2k).



Figure 2-8: Flush mounting with holes in the Vector Compact (n2k)

Note: You do not necessarily need to orient the antenna precisely as you can enter a software offset to accommodate for any bias in heading measurement due to installation.

Before flush mounting the Vector Compact (n2k)

- Determine your mounting orientation. See “Mounting Orientation” on page 9 for more information.
- Choose a location that meets the mounting location requirements.
- Using the fixed base as a template, mark and drill the mounting holes as necessary for the mounting surface.

Flush mounting the Vector Compact (n2k)

1. Mark the mounting hole centers and connector center on the mounting surface.
2. Place the Vector Compact (n2k) over the marks to ensure the planned hole centers align with the true hole centers (adjusting as necessary).
3. Use a center punch to mark the hole centers.
4. Drill the mounting holes to a diameter of 6.8mm (0.26 in) appropriate for the surface.
5. Drill the connector hole to a diameter of 28.6mm (1.13 in) appropriate for the surface.
6. Pull the cable through the center connector hole and attach the cable directly to the Vector Compact (n2k), ensuring the connector is fastened securely to the unit.
7. Place the Vector Compact (n2k) over the mounting holes and insert the mounting screws through the top of the Vector Compact (n2k) and through the mounting surface.
8. Use two M6 washers and M6 nuts to secure the Vector Compact (n2k) to the mounting plate (washers and nuts not included).

▲WARNING: When installing the Vector Compact (n2k), hand tighten only. Damage resulting from over-tightening is not covered by the warranty.

Pole Mount



Before pole mounting the Vector Compact (n2k)

- Determine your mounting orientation. See “Mounting Orientation” on page 9 for more information.
- Choose a location that meets the mounting location requirements.
- Mark and drill the mounting holes as necessary for the threaded pole.

Pole mounting instructions for Vector Compact (n2k) (Inside Pole)

Required tools: 5 mm Allen key for M6 screws and adjustable wrench to tighten jam nut

1. Insert mating cable through both the jam nut and 1" (25.4mm) mounting adapter base
2. Place the jam nut on the pole followed by the 1" (25.4mm) adapter base. Hand tighten the base to the desired orientation.
3. Adjust the jam nut to secure the orientation.
4. Connect the mating end of the cable to the Vector Compact (n2k) connector located on the bottom of the unit.
5. Insert the base adapter into Vector Compact (n2k) by placing the tongue of the base into the groove of the Vector Compact (n2k) unit. When the tongue is properly seated in the groove, the rest of the base can be pressed into place to create a smooth seam between the base and Vector Compact (n2k) unit.
6. Use 5 mm Allen key to fasten two M6 screws to secure Vector Compact (n2k) onto adapter. Use 15 in-lb torque
7. Insert each o-ring onto a plastic cap
8. Install plastic cap with o-ring onto Vector Compact (n2k) unit (rectangular notch faced towards the outside)
9. Align and set the direction of Vector Compact (n2k) unit, while using the jam nut to secure the unit (hand-tighten).

⚠WARNING: Over-tightening may damage the system. This is not covered under warranty.

Pole mounting instructions for Vector Compact (n2k) (Outside Pole)

Required tools: 5 mm Allen key for M6 screws and adjustable wrench to tighten jam nut

1. Place the jam nut on the pole followed by the 1" (25.4mm) adapter base. Hand tighten the base to the desired orientation.
2. Adjust the jam nut to secure the orientation.
3. Run the cable throughout the vessel making sure to leave enough slack to mate the NMEA 2000 cable to both the NMEA 2000 backbone and the Vector Compact (n2k) unit.
4. Run the NMEA 2000 cable through the opening in the side of the pole mounting adapter. And then connect the mating end of the cable to the V104 connector located on the bottom of the unit.
5. Insert the base adapter into Vector Compact (n2k) by placing the tongue of the base into the groove of the Vector Compact (n2k) unit. When the tongue is properly seated in the groove, the rest of the base can be pressed into place to create a smooth seam between the base and Vector Compact (n2k) unit.
6. Use 5 mm Allen key to fasten two M6 screws to secure Vector Compact (n2k) onto adapter. Use 15 in-lb torque
7. Insert each o-ring onto a plastic cap
8. Install plastic cap with o-ring onto Vector Compact (n2k) unit (rectangular notch faced towards the outside)
9. Align and set the direction of Vector Compact (n2k) unit, while using the jam nut to secure the unit (hand-tighten).

⚠ WARNING: Over-tightening may damage the system. This is not covered under warranty.

Connecting the NMEA 2000 cable

1. Align the NMEA 2000 cable connector key-way with the Vector Compact (n2k) connector key.

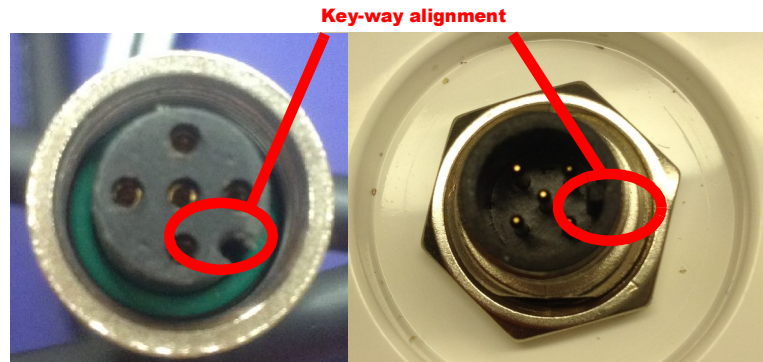

2. Rotate the cable ring clockwise until it is secured firmly to the unit (hand-tighten).

Powering and Connecting to the Vector Compact (n2k)

Power Considerations

For best performance, use clean and continuous power. The Vector Compact (n2k) power supply features reverse polarity protection but will not operate with reverse polarity.

See Table B-3 on page 43 for complete power specifications.

⚠ WARNING: Do not apply a voltage higher than 36 VDC. This will damage the receiver and void the warranty.

Electrical Isolation

The Vector Compact (n2k)'s power supply is isolated from the communication lines and the PC-ABS plastic enclosure isolates the electronics mechanically from the vessel (addressing the issue of vessel hull electrolysis).

NMEA 2000 Cable Pin-out Specifications

Figure 2-9 show the power/data cable pin-out, while Table 2-1 shows the cable's pin-out specifications.

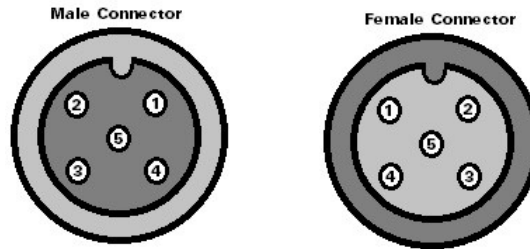

Figure 2-9: NMEA 2000 cable pin assignment

Table 2-1: NMEA 2000 cable pin-out

Pin	Function
1	Shield
2	Power Supply Positive (+V)
3	Power Supply Negative (-V)
4	CAN HI
5	CAN LOW

NMEA 2000 Port

The Vector Compact (n2k) uses proprietary NMEA 2000 PGN for receiver configuration. Please contact customerservice@si-tex.com for a complete and up to date list of available proprietary PGN's. With suitable USB-CAN hardware from Kvaser or PEAK, Vector Compact (n2k) can be connected to a Windows PC to use PocketMax or VectorPC for configuration and setup using the same serial commands as the NMEA0183 Vector Compact (n2k).

Chapter 2: Installation

Chapter 3: Operation

GPS Overview

Vector Compact

(n2k) Overview

Common Commands and Messages

GPS Overview

For your convenience, both the GPS and SBAS (WAAS, MSAS, GAGAN and EGNOS) operation of the Vector Compact (n2k) features automatic operational algorithms. When powered for the first time, the Vector Compact (n2k) performs a "cold start," which involves acquiring the available GPS satellites in view and the SBAS differential service.

GPS Operation

The GPS receiver is always operating, regardless of the DGPS mode of operation. The following sections describe the general operation of the Vector Compact (n2k)'s internal GPS receiver.

Note: Differential source and status have no impact on heading, pitch, or roll. They only have an impact on position and heave.

Automatic Tracking

The Vector Compact (n2k)'s internal GPS receiver automatically searches for GPS satellites, acquires the signals, and manages the navigation information required for position and tracking.

Receiver Performance

The Vector Compact (n2k) works by finding four or more GPS satellites in the visible sky. It uses information from the satellites to compute a position within 3 m. Since there is some error in the GPS data calculations, the Vector Compact (n2k) also tracks a differential correction. The Vector Compact (n2k) uses these corrections to improve its position accuracy to better than 1.0 m.

There are two main aspects of GPS receiver performance:

- Satellite acquisition
- Position and heading calculation

When the Vector Compact (n2k) is properly positioned, the satellites transmit coded information to the antennas on a specific frequency. This allows the receiver to calculate a range to each satellite from both antennas. GPS is essentially a timing system. The ranges are calculated by timing how long it takes for the

signal to reach the GPS antenna. The GPS receiver uses a complex algorithm incorporating satellite locations and ranges to each satellite to calculate the geographic location and heading. Reception of any four or more GPS signals allows the receiver to compute three-dimensional coordinates and a valid heading.

Differential Operation

The purpose of differential GPS (DGPS) is to remove the effects of selective availability (SA), atmospheric errors, timing errors, and satellite orbit errors, while enhancing system integrity. Autonomous position capabilities of the Vector Compact (n2k) will result in position accuracies of 3 m 95% of the time. In order to improve position quality to better than 1.0 m 95%, the Vector Compact (n2k) is able to use differential corrections received through the internal SBAS demodulator.

Automatic SBAS Tracking

The Vector Compact (n2k) automatically scans and tracks SBAS signals without the need to tune the receiver. The Vector Compact (n2k) features two-channel tracking that provides an enhanced ability to maintain a lock on an SBAS satellite when more than one satellite is in view. This redundant tracking approach results in more consistent tracking of an SBAS signal in areas where signal blockage of a satellite is possible.

Vector Compact (n2k) Overview

The Vector Compact (n2k) provides accurate and reliable heading and position information at high update rates. To accomplish this task, the Vector Compact (n2k) uses a high performance GPS receiver and two antennas for GPS signal processing. One antenna is designated as the primary GPS antenna and the other is the secondary GPS antenna. Positions computed by the Vector Compact (n2k) are referenced to the phase center of the primary GPS antenna. Heading data references the vector formed from the primary GPS antenna phase center to the secondary GPS antenna phase center.

The heading arrow located on the bottom of the Vector Compact (n2k) enclosure defines system orientation. The arrow points in the direction the heading measurement is computed (when the antenna is installed parallel to the fore-aft line of the vessel). The secondary antenna is directly above the arrow.

Supplemental Sensors

The Vector Compact (n2k) has an integrated gyro and two tilt sensors. The gyro and tilt sensors are enabled by default. Both supplemental sensors are mounted on the printed circuit board inside the Vector Compact (n2k).

The sensors act to reduce the search volume, which improves heading startup and reacquisition times. This improves the reliability and accuracy of selecting the correct heading solution by eliminating other possible, erroneous solutions. Table 3-1 on page 27 provides a sensor operation summary.

Table 3-1: Sensor operation summary

Feature	Normal Operation	Coasting (no GPS)
Heading	GPS	Gyro
Pitch	GPS	Inertial sensor
Roll	Inertial sensor	Inertial sensor

Tilt Aiding

The Vector Compact (n2k)'s accelerometers (internal tilt sensors) are factory-calibrated and enabled by default. This allows for a steady heading solution beyond the volume associated with just a fixed antenna separation. This is because the Vector Compact (n2k) knows the approximate inclination of the secondary antenna with respect to the primary antenna. The search space defined by the tilt sensor will be reduced to a horizontal ring on the sphere's surface by reducing the search volume. This considerably decreases startup and reacquisition times (see Figure 3-1).

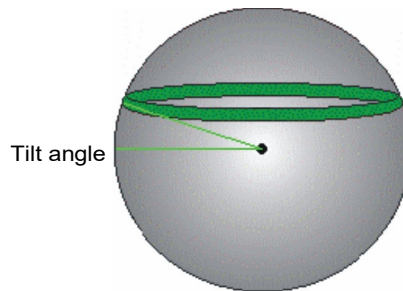

Figure 3-1: Vector Compact (n2k)'s tilt aiding

Gyro Aiding

The Vector Compact (n2k)'s internal gyro offers several benefits. It reduces the sensor volume to shorten reacquisition times when a GPS heading is lost because the satellite signals were blocked. The gyro provides a relative change in angle since the last computed heading, and, when used in conjunction with

the tilt sensor, defines the search space as a wedge-shaped location (see Figure 3-2).

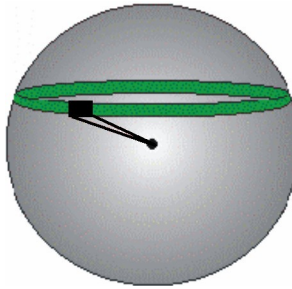

Figure 3-2: Vector Compact (n2k)'s gyro aiding

The gyro aiding accurately smooths the heading output and the rate of turn. It provides an accurate substitute heading for a short period depending on the roll and pitch of the vessel, ideally seeing the system through to reacquisition. The gyro provides an alternate source of heading, accurate to within 1° per minute for up to three minutes, in times of GPS loss for either antenna. If the outage lasts longer than three minutes, the gyro will have drifted too far and the Vector Compact (n2k) begins outputting null fields in the heading output messages. There is no user control over the timeout period of the gyro.

Calibration, which is set at the factory, is required for the gyro to remove latency from the heading solution as well as provide backup heading when GPS is blocked. The receiver will calibrate itself after running for a while but it may be important to follow the manual calibration instructions if you want to guarantee performance quickly after powering up the receiver.

With the gyro enabled, the gyro is also used to update the post HTAU smoothed heading output from the GPS heading computation. This means that if the HTAU value is increased while gyro aiding is enabled, there will be no lag in heading output due to vehicle maneuvers. Hemisphere GNSS' GPS Technical Reference includes information on setting an appropriate HTAU value for the application.

Time Constants

The Vector Compact (n2k) incorporates user-configurable time constants that can provide a degree of smoothing to the heading, pitch, rate of turn (ROT), course over ground (COG), and speed measurements. You can adjust these parameters depending on the expected dynamics of the vessel. For example, increasing the time is reasonable if the vessel is very large and is not able to turn quickly or would not pitch quickly. The resulting values would have reduced “noise,” resulting in consistent values with time. However, if the vessel is quick and nimble, increasing this value can create a lag in measurements. Formulas for determining the level of smoothing are located in Hemisphere GNSS’ GPS Technical Reference. If you are unsure on how to set this value, it is best to be conservative and leave it at the default setting.

Note: For heading and rate of turn there is no lag once the gyro is calibrated and enabled.

Rate of Turn (ROT) time constant: The default value of this constant is 2.0 seconds of smoothing. Increasing the time constant increases the level of ROT smoothing.

Course Over Ground (COG) time constant: The default value of this constant is 0.0 seconds of smoothing. Increasing the time constant increases the level of COG smoothing. COG is computed using only the primary GPS antenna and its accuracy depends upon the speed of the vessel (noise is proportional to 1/speed). This value is invalid when the vessel is stationary, as tiny movements due to calculation inaccuracies are not representative of a vessel’s movement.

Speed time constant: The default value of this constant is 0.0 seconds of smoothing. Increasing the time constant increases the level of speed measurement smoothing.

Watchdog

The watchdog is a timer that is controlled by the software that monitors if the heading is lost. The watchdog software is compliant with IEC 60945.

Common Commands and Messages

Table 3-2 below through Table 3-3 provide brief descriptions of common NMEA commands and messages for the Vector Compact (n2k). Refer to the SI-TEX Marine Electronics GPS Technical Reference for more detailed information

Table 3-2: Received messages based on a request

PG No. (PGN)	Description	Default Update Rate (msec)	Freq. (Hz)
059392	ISO Acknowledgment Used to acknowledge the status of certain requests addressed to a specific ECU.	On Request	On Request
059904	ISO Request Request the transmission of a specific PGN, addressed or broadcast.	On Request	On Request
060928	ISO Address Claim Used to identify to other ECUs the address claimed by an ECU.	On Request	On Request
126996	Product Information NMEA 2000 database version supported, manufacturer's product code, NMEA 2000 certification level, Load Equivalency number, and other product-specific information.	On Request	On Request
126464	Receive/Transmit PGNs group function The Transmit/Receive PGN List Group type of function is defined by first field. The message will be a Transmit or Receive PGN List group function.	On Request	On Request
129538	GNSS Control Status GNSS common satellite receiver parameter status.	On Request	On Request

PG No. (PGN)	Description	Default Update Rate (msec)	Freq. (Hz)
129545	GNSS RAIM Output Autonomous Integrity Monitoring (RAIM) process. The Integrity field value is based on the parameters set in PGN 129546 GNSS RAIM settings.	On Request	On Request
129546	GNSS RAIM Settings Used to report the control parameters for a GNSS Receiver Autonomous Integrity Monitoring (RAIM) process.	On Request	On Request

Table 3-3: Transmitted messages

PG No. (PGN)	Description	Default Update Rate (msec)	Freq. (Hz)
126992	System Time The purpose of this PGN is twofold: to provide a regular transmission of UTC time, date, and to provide synchronism for measurement data.	1000	1
127250	Vessel Heading Heading sensor value with a flag for True or Magnetic. If the sensor value is Magnetic, the deviation field can be used to produce a Magnetic heading, and the variation field can be used to correct the Magnetic heading to produce a True heading.	100	10
127251	Rate of Turn Rate of change of the Heading.	100	10

PG No. (PGN)	Description	Default Update Rate (msec)	Freq. (Hz)
127257	<p>Attitude</p> <p>Provides a single transmission that describes the position of a vessel relative to both horizontal and vertical planes. This would typically be used for vessel stabilization, vessel control and on-board platform stabilization.</p>	1000	1
127258	<p>Magnetic Variation</p> <p>Message for transmitting variation. The message contains a sequence number to allow synchronization of other messages such as Heading or Course over Ground. The quality of service and age of service are provided to enable recipients to determine an appropriate level of service if multiple transmissions exist.</p>	1000	1
129025	<p>Position, Rapid Update</p> <p>Provides latitude and longitude referenced to WGS84. Being defined as single frame message, as opposed to other PGNs that include latitude and longitude and are defined as fast or multi-packet, this PGN lends itself to being transmitted more frequently without using up excessive bandwidth on the bus for the benefit of receiving equipment that may require rapid position updates.</p>	100	10
129026	<p>COG & SOG, Rapid Update</p> <p>Single frame PGN that provides Course Over Ground (COG) and Speed Over Ground (SOG).</p>	250	4

Chapter 3: Operation

PG No. (PGN)	Description	Default Update Rate (msec)	Freq. (Hz)
129027	<p>PositionDelta, HighPrecisionRapidUpdate</p> <p>The "Position Delta, High Precision Rapid Update" Parameter Group is intended for applications where very high precision and very fast update rates are needed for position data. This PGN can provide delta position changes down to 1 mm with a delta time period accurate to 5 msec.</p>	100	10
129028	<p>AltitudeDelta, High Precision Rapid Update</p> <p>The "Altitude Delta, High Precision Rapid Update" Parameter Group is intended for applications where very high precision and very fast update rates are needed for altitude and Course Over Ground data. This PGN can provide delta altitude changes down to 1 millimeter, a change in direction as small as 0.0057°, and with a delta time period accurate to 5 msec.</p>	100	10
129029	<p>GNSS Position Data</p> <p>Conveys a comprehensive set of Global Navigation Satellite System (GNSS) parameters, including position information.</p>	1000	1
129033	<p>Time & Date</p> <p>Single transmission that provides UTC time, UTC Date, and Local Offset.</p>	1000	1
129539	<p>GNSS DOPs</p> <p>Provides a single transmission containing GNSS status and dilution of precision components (DOP) that indicate the contribution of satellite geometry to the overall position error. There are three DOP parameters reported: horizontal (HDOP), vertical (VDOP), and time (TDOP).</p>	1000	1

PG No. (PGN)	Description	Default Update Rate (msec)	Freq. (Hz)
129540	GNSS Sats in View GNSS information on current satellites in view tagged by sequence ID. Information includes PRN, elevation, azimuth, SNR, defines the number of satellites; defines the satellite number and the information.	1000	1
129542	GNSS Pseudorange Noise Statistics GNSS pseudorange measurement noise statistics can be translated in the position domain in order to give statistical measures of the quality of the position solution. Intended for use with a Receiver Autonomous Integrity Monitoring (RAIM) application	1000	1

Table 3-4: Single Frame packet definition - PGN: EFX (Destination addressable)

MSGIDs	Description
0x0001	N2K,MCODE
0x0002	N2K,PCODE
0x0003	N2K,LOAD
0x0004	N2K,CERT
0x0005	JVERSION
0x0006	N2K,RESET
0x0007	N2K,ADDRESS
0x0008	JDIFF
0x0009	JDIFF,INCLUDE

Table 3-4: Single Frame packet definition - PGN: EFX (Destination addressable)

MSGIDs	Description
0x000A	JMODES
0x000B	JSBASPRN
0x000C	JBAUD,PORTx
0x000	JMASK
0x000E	JATT,TILTAID
0x000F	JATT,TILTCAL
0x0010	JATT,HBIAS
0x0011	JATT,PBIAS
0x0012	JATT,GYROAID
0x0013	JRESET
0x0014	Jl, serial number
0x0015	JRAIM
0x0016	JATT,HIGHMP
0x0017	JAPP
0x0018	JAGE
0x0019	BIN1, stdev residuals
0x00A	RD1
0x001B	JK (read)
0x001C	File Transfer Details
0x001	JWCONF,12
0x001E	GNSS receiver boot loader reply messages
0x001F	Jl, application version

Table 3-4: Single Frame packet definition - PGN: EFXX (Destination addressable)

MSGIDs	Description
0x0020	JSYSVER
0x0021	JT
0x0022	JATT,MSEP
0x0023	JATT,CSEP
0x0024	ERROR
0x0025	NMEA 2000 Message Control
0x0026	JNP
0x0027	JSMOOTH
0x0028	JATT,HTAU
0x0029	JATT,HRTAU
0x002A	JATT,COGTAU
0x002B	JATT,SPDTAU
0x002C	JATT,NEGILT
0x002	JATT,FLIPBRD
0x002E	JATT,LEVEL
0x002F	JATT,MOVEBAS
0x0030	CANMODE
0x0031	GPHEV Heave
0x0032	JSAVE
0x0033	DIAGNOSTICS
0x0034	INTLT Raw Tilt Values

Table 3-5: Multi-Frame Fast Packet definition: PGN: 1EFFF (Destination addressable)

MSGIDs	Description
0x8001	N2K,VERSION
0x8002	JK (write)
0x8003	JPOSOFFSET
0x8004	JVERSION
0x8005	JAUTH
0x8006	File Transfer Data Packet
0x8007	GNSS Boot loader Message
0x8008	Generic GNSS Serial Command
0x8009	RAW data transfer for differential
0x800A	Jl, Extended info
0x800B	N2K,MODEL

Chapter 3: Operation

Appendix A: Troubleshooting

Appendix A: Troubleshooting

Table A-1 provides troubleshooting for common problems.

Table A-1: Troubleshooting

Symptom	Possible Solution
Receiver fails to power	<ul style="list-style-type: none"> • Check integrity of power cable connectors • Check power input voltage (6 to 36 VDC) • Check current restrictions imposed by power source (minimum available should be > 1.0 A)
No data from Vector Compact (n2k)	<ul style="list-style-type: none"> • Check receiver power status to ensure the receiver is powered (an ammeter can be used for this) • Check integrity and connectivity of power and data cable connections
No GPS lock	<ul style="list-style-type: none"> • Verify the Vector Compact (n2k) has a clear view of the sky • Verify the lock status of GPS satellites
No SBAS lock	<ul style="list-style-type: none"> • Verify the Vector Compact (n2k) has a clear view of the sky • Verify the lock status of SBAS satellites <p>Note: SBAS lock is only possible if you are in an appropriate SBAS region; currently, there is limited SBAS availability in the southern hemisphere.</p>
No heading or incorrect heading value	<ul style="list-style-type: none"> • Heading is from primary GPS antenna to secondary GPS antenna, so the arrow on the underside of the Vector Compact (n2k) should be directed to the bow side • Monitor the number of satellites and SNR values for both antennas - at least four satellites should have strong SNR values

Appendix B: Specifications

Table B-1 through Table B-5 provide the Vector Compact (n2k)'s GPS sensor, communication, power, mechanical, and environmental specifications.

Table B-1: GPS sensor specifications

Item	Specification
Receiver type	Vector GPS L1 Compass
Channels	Two 12-channel, parallel tracking (Two 10-channel when tracking SBAS)
SBAS tracking	2-channel, parallel tracking
Update rate	10 Hz standard (position and heading)
Position accuracy	
Single Point ¹	1 m (95%)
SBAS ²	3 m (95%)
Heading accuracy	2° (RMS)
Heave accuracy ³	< 30 cm (RMS)
Pitch/Roll accuracy	2° (RMS)
Rate of turn	90°/s maximum
Cold start	< 60 s typical (no almanac or RTC)
Warm start	< 20 s typical (almanac and RTC)
Hot start	< 1 s typical (almanac, RTC, and position)
Heading fix	< 10 s typical (valid position)
Compass safe distance	30 cm (11.8 in)
Maximum speed	1,850 kph (999 kts)
Maximum altitude	18,288 m (60,000 ft)

Appendix B: Specifications

Table B-2: Communication specifications

Item	Specification
Port	NMEA 2000
Data I/O protocol	NMEA 2000 and CANOpen

Table B-3: Power specifications

Item	Specification
Input voltage	8 to 36 VDC
Power consumption	~ 2.0 W nominal
Current consumption	165 mA @ 12 VDC
Power isolation	Isolated to enclosure
Reverse polarity protection	Yes

Table B-4: Mechanical specifications

Item	Specification
Enclosure	UV resistant, white plastic, Geloy CR7520 (ASA)
Dimensions (not including mount)	25.9 L x 12.9 W x 4.5 H (cm) 10.2 L x 5.1 W x 1.8 H (in)
Dimensions (including mount)	25.9 L x 12.9 W x 12.8 H (cm) 10.2 L x 5.1 W x 5.0 H (in)
Weight (not including mount)	0.42 kg (0.9 lb)
Weight (including mount)	0.51 kg (1.1 lb)

Table B-5: Environmental specifications

Item	Specification
Operating temperature	-30°C to +70°C (-22°F to +158°F)

Table B-5: Environmental specifications (continued)

Item	Specification
Storage temperature	-40°C to +85°C (-40°F to +185°F)
Water and Dust	IP69
Humidity	100% non-condensing
Vibration	IEC 60945
EMC	CE (IEC 60945 Emissions and Immunity) FCC Part 15, Subpart B CISPR22F

¹Depends on multipath environment, number of satellites in view, satellite geometry, no SA, and ionospheric activity.

²Depends on multipath environment, number of satellites in view, SBAS coverage and satellite geometry.

³Based on a 40-second time constant.

Index

A

alarm
 watchdog 29
alignment 11
automatic
 SBAS tracking 25
 tracking 24

C

COGTAU 29
commands (common) 30
common commands and messages 30
communication specifications 43
connect
 to a power source 20
course over ground time constant 29

E

electrical isolation 20
environmental
 considerations 6
 specifications 43
environmental considerations 6

F

flush mount 15

G

GPS
 automatic SBAS tracking 25
 automatic tracking 24
 operation 24
 overview 24
 receiver performance 24

 reception 6
 sensor specifications 42
gyro aiding 27

H

heave
 accuracy 42
HRTAU 29

L

long sight alignment 11

M

mechanical specifications 43
message (common) 30
mounting
 alignment 11
 environmental considerations 6
 flush mount 15
 GPS reception 6
 location 6
 orientation 9
 parallel orientation 9
 perpendicular orientation 9
 pole mount 17
 VHF interference 7

O

orientation for mounting 9

P

parallel mounting 9
part numbers 3
parts list 3

- perpendicular mounting 9
- pole mount 17
- power
 - connecting to a power source 20
 - considerations 20
 - electrical isolation 20
 - specifications 43

R

- rate of turn (ROT) time constant 29
- receiver performance 24
- RS-232 21

S

- sensor specifications 42
- short site alignment 11
- SPDTAU 29
- specifications
 - communication 43
 - environmental 43
 - GPS sensor 42
 - mechanical 43
 - power 43
- speed time constant 29
- supplemental sensors 26

T

- tilt aiding 27
- time constants 29
 - COGTAU 29
 - HRTAU 29
 - SPDTAU 29
- tracking
 - automatic 24
 - automatic SBAS 25
- troubleshooting 40

V

- VHF interference 7

W

- watchdog 29

SI-TEX CERTIFICATE OF LIMITED WARRANTY

Providing you present valid proof of purchase, SI-TEX Marine Electronics warrants all parts of each new product against defects in material and workmanship under normal use and will repair or exchange any parts proven to be defective at no charge for a period of two years from the original date of purchase, except as provided below under Limited Warranty Exceptions.

Defects will be corrected during normal working hours by an authorized SI-TEX Marine Electronics dealer, service center, or at the SI-TEX office in Riverhead, NY. There will be no charge for repair labor for a period of one year from the date of purchase, except as provided below under Limited Warranty Exceptions. This Warranty and Proof of Purchase must be made available to the authorized SI-TEX Marine Electronics service location or dealer at the time of service.

LIMITED WARRANTY EXCEPTIONS

SI-TEX Marine Electronics will not be responsible for equipment which has been subjected to water or lightning damage, accident, abuse, or misuse, nor any equipment on which the serial number has been removed, altered, or mutilated. SI-TEX Marine Electronics assumes no responsibility for damage incurred during installation. This Limited Warranty is effective only with respect to the original purchaser. Any cost associated with transducer replacement, other than the cost of the transducer itself, is specifically excluded from the Limited Warranty.

Travel cost incurred will not be accepted by SI-TEX Marine Electronics
THERE ARE NO WARRANTIES WHICH EXTEND BEYOND THE DESCRIPTION ON THE FACE HEREOF.

SPECIFIC EXCLUSIONS

Charges for overtime, stand-by, holiday, and per diem are specifically excluded from the Limited Warranty. fuses are consumable items and are not covered by this Limited Warranty. Installation workmanship or materials, except as provided directly by SI-TEX Marine Electronics are not covered by this Limited Warranty.

SI-TEX Marine Electronics equipment, or parts thereof which have been repaired or altered except by an authorized SI-TEX Marine Electronics dealer or service center are not warranted in any respect. Transducers, software updates, batteries, magnetrons and microwave components, are items excluded from the two-year warranty and are covered by warranty for a period of one year for both parts and labor.

SI-TEX Marine Electronics will not, at any time assume any costs or labor charges for checkout or external line fuse replacement or problems not found to be at fault in the equipment itself.

THERE ARE NO WARRANTIES OR GUARANTEES EXPRESSED OR IMPLIED WHICH EXTEND BEYOND THE DESCRIPTION OF THE FACE HEREOF, INCLUDING WARRANTIES OF FITNESS FOR A PARTICULAR PURPOSE AND MERCHANTABILITY. SI-TEX MARINE ELECTRONICS HAS NO OTHER LIABILITY TO PURCHASE FOR DIRECT OR CONSEQUENTIAL DAMAGE OR ANY THEORY INCLUDING ABSOLUTE LIABILITY, TORT, OR CONTRACT. THIS LIMITED WARRANTY CANNOT BE ALTERED OR MODIFIED IN ANY WAY AND SHALL BE INTERPRETED IN ACCORDANCE WITH THE LAWS OF THE STATE OF NEW YORK. THIS WARRANTY IS LIMITED TO THE CONTINENTAL U.S.A., ALASKA, HAWAII, AND CANADA.

MAILING & SHIPPING ADDRESS:
SI-TEX Marine Electronics
25 Enterprise Zone Drive, suite #2
Riverhead, NY 11901
(631) 996-2690

HOW TO OBTAIN SERVICE UNDER THIS WARRANTY

To provide greater flexibility, SI-TEX Marine Electronics gives you the option to obtain service under the warranty by either:

(a) Contacting an authorized SI-TEX Marine Electronics service station

V104n GPS Compass User Guide

(The closest service station may be found by contacting your dealer of purchase)

OR

(b) Shipping your equipment prepaid via UPS, FED-EX or truck with insurance prepaid to SI-TEX Marine Electronics. at the address provided below. SI-TEX Marine Electronics will whenever possible, make all repairs covered by Limited Warranty within two weeks of receiving the equipment in New York and return the same to you, freight prepaid.

Please do not use the Mail Service due to delays in tracing lost packages.

(c) You must present a copy of your Purchase Sales Slip at the time you request warranty service.

A product repair case can be started from the support section of our website at **www.si-tex.com**

Online Repair Case Portal:

<https://sitexservice.bluefolder.com/classic/portal/index.aspx>



Customer Service

If you encounter problems during the installation or operation of this product, or cannot find the information you need, please contact Sitex Customer Service.

The contact numbers and e-mail address for Sitex Customer Service are:

Sitex Main Office.....+1-631-996-2690

Sitex Fax.....+1-631-996-2693

Sitex Service E-mail address: service@si-tex.com

Sitex Customer Support E-mail address: customerservice@si-tex.com

Sitex Main Office Address:

25 Enterprise Zone Drive, Ste 2

Riverhead, NY 11901

Technical Support is available from 9:00 AM to 5:00 PM Eastern Standard Time, Monday through Friday.



25 Enterprise Zone Drive, Ste 2
Riverhead, NY 11901

Tel: 631-996-2690

Fax: 631-996-2693

Email: customerservice@si-tex.com